



GEARBOXES

TWIN DISC GEARBOXES

Our gearboxes are built to withstand the most rigorous applications on the planet. Their modular design features cast iron housings, shaved helical gears and case hardened shafts. Twin Disc gearboxes are available with reduction and increaser gear ratios on outputs, along with output rotation options.

TWIN DISC GEARBOXES

INCLUDE THE FOLLOWING DESIGN FEATURES:

- Reduction & increaser gear ratios on outputs
- Cast iron housings
- Shaved helical gears
- Case hardened shafts
- Output rotation options
- Modular design

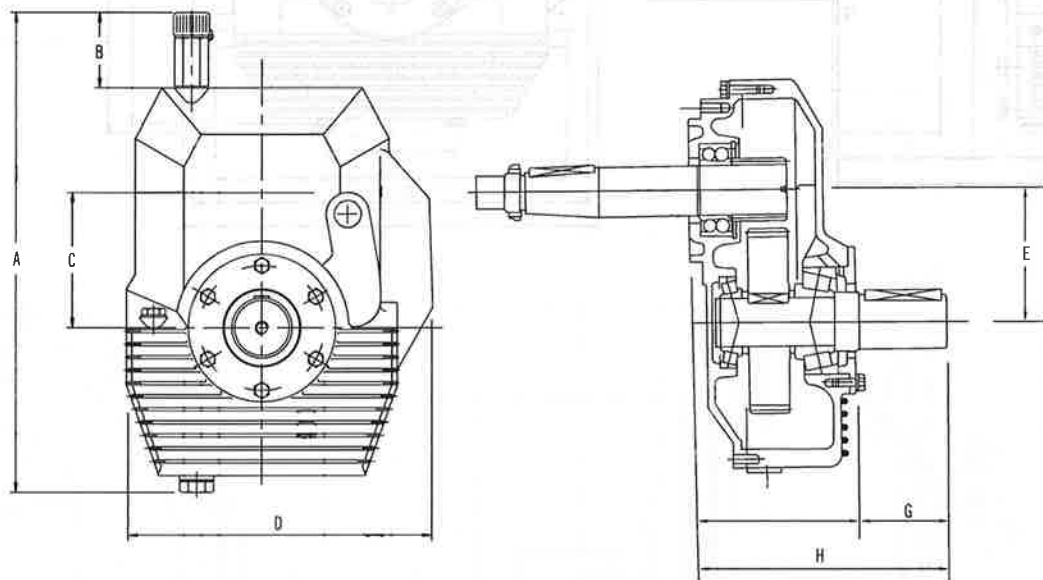

Gearbox Dimensional Data – mm (in)

	A	B	C	D	E	F	G	H
RM20	301.0 (11.85)	64.5 (2.54)	67.5 (2.66)	192.0 (7.56)	67.5 (2.66)	107.0 (4.21)	50.0 (1.97)	157.0 (6.18)
RM45	375.0 (14.76)	68.5 (2.70)	88.5 (3.48)	233.0 (9.17)	88.5 (3.48)	131.0 (5.16)	70.0 (2.76)	201.0 (7.91)
RM70	443.0 (17.44)		121.5 (4.78)	283.0 (11.14)	121.5 (4.78)	142.0 (5.59)	80.0 (3.15)	222.0 (8.74)
RM100	459.0 (18.07)		135.0 (5.31)	311.0 (12.24)	135.0 (5.31)	172.0 (6.77)	120.0 (4.72)	292.0 (11.50)
RM120	545.0 (21.46)		160.0 (6.30)	378.0 (14.88)	160.0 (6.30)	200.0 (7.87)	140.0 (5.51)	340.0 (13.39)
RM150	613.0 (24.13)		189.0 (7.44)	419.0 (16.50)	189.0 (7.44)	262.0 (10.31)	140.0 (5.51)	402.0 (15.83)

RM 20 SERIES

RM 20D FOR REVERSE DIRECTION AS ENGINE OUTPUT
RM 20S FOR SAME DIRECTION AS ENGINE OUTPUT

RM 20D – series (Reversing Gearboxes)

Ratio (X:1)	Part Number	Configuration	Max. Input Torque Nm (lb-ft)	Max. Power Allowed Without H.E. kW (hp)	Maximum Input Shaft Speed	SAE Housing	Clutch Size
0.57	IR11311004	Housing	75 (56)	15 (20)	2700	5	6.5"
1.00	IR11311005		75 (56)		3500		
2.00	IR11311006		55 (41)				
2.71	IR11311007		50 (37)				
0.57	IR11321004	Housing	75 (56)	15 (20)	2700	5	7.5"
1.00	IR11321005		75 (56)		3500		
2.00	IR11321006		55 (41)				
2.71	IR11321007		50 (37)				
0.57	IR11111004	with BD110 PTO	75 (56)	15 (20)	2700	5	6.5"
1.00	IR11111005		75 (56)		3500		
2.00	IR11111006		55 (41)				
2.71	IR11111007		50 (37)				
0.57	IR11111104	with BD110 PTO	75 (56)	15 (20)	2700	5	7.5"
1.00	IR11111105		75 (56)		3500		
2.00	IR11111106		55 (41)				
2.71	IR11111107		50 (37)				
0.57	IR11122004	with BD112 PTO	75 (56)	15 (20)	2700	4	7.5"
1.00	IR11122005		75 (56)		3500		
2.00	IR11122006		55 (41)				
2.71	IR11122007		50 (37)				
0.57	IR11220004	with BDS112 Remote PTO	75 (56)	15 (20)	2700	N/A	N/A
1.00	IR11220005		75 (56)		3500		
2.00	IR11220006		55 (41)				
2.71	IR11220007		50 (37)				

RM 20S – series (Same Direction Gearboxes)

Ratio (X:1)	Part Number	Configuration	Max. Input Torque Nm (lb-ft)	Max. Power Allowed Without H.E. kW (hp)	Maximum Input Shaft Speed	SAE Housing	Clutch Size
0.64	IR11311003	Housing	75 (56)	12 (16)	2800	5	6.5"
1.89	IR11311001		55 (41)		3500		
2.47	IR11311002		50 (37)				
0.64	IR11321003	Housing	75 (56)	12 (16)	2800	5	7.5"
1.89	IR11321001		55 (41)		3500		
2.47	IR11321002		50 (37)				
0.64	IR11111003	with BD110 PTO	75 (56)	12 (16)	2800	5	6.5"
1.89	IR11111001		55 (41)		3500		
2.47	IR11111002		50 (37)				
0.64	IR11111103	with BD110 PTO	75 (56)	12 (16)	2800	5	7.5"
1.89	IR11111101		55 (41)		3500		
2.47	IR11111102		50 (37)				
0.64	IR11122003	with BD112 PTO	75 (56)	12 (16)	2800	4	7.5"
1.89	IR11122001		55 (41)		3500		
2.47	IR11122002		50 (37)				
0.64	IR11220003	with BDS112 Remote PTO	75 (56)	12 (16)	2800	N/A	N/A
1.89	IR11220001		55 (41)		3500		
2.47	IR11220002		50 (37)				



RM 45 SERIES

RM 45D FOR REVERSE DIRECTION AS ENGINE OUTPUT

Ratio (X:1)	Part Number	Configuration	Max. Input Torque Nm (lb-ft)	Max. Power Allowed Without H.E. kW (hp)	Maximum Input Shaft Speed	SAE Housing	Clutch Size
0.67	ITR12311009	Housing	165 (122)	30 (40)	2800	5	6.5"
1.00	ITR12311005		161 (119)		3500		
2.00	ITR12311006		121 (89)				
2.88	ITR12311007		100 (74)				
3.40	ITR12311012		80 (59)				
4.00	ITR12311010		80 (59)				
5.00	ITR12311008		71 (52)				
0.67	ITR12321009	Housing	165 (122)	30 (40)	2800	5	7.5"
1.00	ITR12321005		161 (119)		3500		
2.00	ITR12321006		121 (89)				
2.88	ITR12321007		100 (74)				
3.40	ITR12321012		80 (59)				
4.00	ITR12321010		80 (59)				
5.00	ITR12321008		71 (52)				
0.67	ITR12322009	Housing	165 (122)	30 (40)	2800	4	7.5"
1.00	ITR12322005		161 (119)		3500		
2.00	ITR12322006		121 (89)				
2.88	ITR12322007		100 (74)				
3.40	ITR12322012		80 (59)				
4.00	ITR12322010		80 (59)				
5.00	ITR12322008		71 (52)				
0.67	ITR12332009	Housing	165 (122)	30 (40)	2800	4	8.0"
1.00	ITR12332005		161 (119)		3500		
2.00	ITR12332006		121 (89)				
2.88	ITR12332007		100 (74)				
3.40	ITR12332012		80 (59)				
4.00	ITR12332010		80 (59)				
5.00	ITR12332008		71 (52)				
0.67	ITR12111009	with BD110 PTO	165 (122)	30 (40)	2800	5	6.5"
1.00	ITR12111005		161 (119)		3500		
2.00	ITR12111006		121 (89)				
2.88	ITR12111007		100 (74)				
3.40	ITR12111012		80 (59)				
4.00	ITR12111010		80 (59)				
5.00	ITR12111008		71 (52)				
0.67	ITR12111109	with BD110 PTO	165 (122)	30 (40)	2800	5	7.5"
1.00	ITR12111105		161 (119)		3500		
2.00	ITR12111106		121 (89)				
2.88	ITR12111107		100 (74)				
3.40	ITR12111112		80 (59)				
4.00	ITR12111110		80 (59)				
5.00	ITR12111108		71 (52)				
0.67	ITR12122109	with BD112 PTO	165 (122)	30 (40)	2800	4	7.5"
1.00	ITR12122105		161 (119)		3500		
2.00	ITR12122106		121 (89)				
2.88	ITR12122107		100 (74)				
3.40	ITR12122112		80 (59)				
4.00	ITR12122110		80 (59)				
5.00	ITR12122108		71 (52)				
0.67	ITR12122009	with BD112 PTO	165 (122)	30 (40)	2800	4	8.0"
1.00	ITR12122005		161 (119)		3500		
2.00	ITR12122006		121 (89)				
2.88	ITR12122007		100 (74)				
3.40	ITR12122012		80 (59)				
4.00	ITR12122010		80 (59)				
5.00	ITR12122008		71 (52)				
0.67	ITR12132009	with BD118 PTO	165 (122)	30 (40)	2800	4	8.0"
1.00	ITR12132005		161 (119)		3500		
2.00	ITR12132006		121 (89)				
2.88	ITR12132007		100 (74)				
3.40	ITR12132012		80 (59)				
4.00	ITR12132010		80 (59)				
5.00	ITR12132008		71 (52)				
0.67	ITR12230009	with BDS118 Remote PTO	165 (122)	30 (40)	2800	N/A	N/A
1.00	ITR12230005		75 (56)	15 (20)	3500		
2.00	ITR12230006		121 (89)				
2.88	ITR12230007		100 (74)				
3.40	ITR12230012		80 (59)				
4.00	ITR12230010		80 (59)				
5.00	ITR12230008		71 (52)				

RM 45 SERIES

RM 45S FOR SAME DIRECTION AS ENGINE OUTPUT

Ratio (x :1)	Part Number	Configuration	Max. Input Torque Nm (lb-ft)	Max. Power Allowed Without H.E. kW (hp)	Maximum Input Shaft Speed	SAE Housing	Clutch Size
0.57	ITR12311004	Housing	161 (119)	24 (32)	2700	5	6.5"
1.50	ITR12311011		130 (96)		3500		
1.81	ITR12311001		110 (81)				
2.65	ITR12311002		91 (67)				
4.09	ITR12311003		71 (52)				
0.57	ITR12321004	Housing	161 (119)	24 (32)	2700	5	7.5"
1.50	ITR12321011		130 (96)		3500		
1.81	ITR12321001		110 (81)				
2.65	ITR12321002		91 (67)				
4.09	ITR12321003		71 (52)				
0.57	ITR12322004	Housing	161 (119)	24 (32)	2700	4	7.5"
1.50	ITR12322011		130 (96)		3500		
1.81	ITR12322001		110 (81)				
2.65	ITR12322002		91 (67)				
4.09	ITR12322003		71 (52)				
0.57	ITR12332004	Housing	161 (119)	24 (32)	2700	4	8.0"
1.50	ITR12332011		130 (96)		3500		
1.81	ITR12332001		110 (81)				
2.65	ITR12332002		91 (67)				
4.09	ITR12332003		71 (52)				
0.57	ITR12111004	with BD110 PTO	161 (119)	24 (32)	2700	5	6.5"
1.50	ITR12111011		130 (96)		3500		
1.81	ITR12111001		110 (81)				
2.65	ITR12111002		91 (67)				
4.09	ITR12111003		71 (52)				
0.57	ITR12111104	with BD110 PTO	161 (119)	24 (32)	2700	5	7.5"
1.50	ITR12111111		130 (96)		3500		
1.81	ITR12111101		110 (81)				
2.65	ITR12111102		91 (67)				
4.09	ITR12111103		71 (52)				
0.57	ITR12122104	with BD112 PTO	161 (119)	24 (32)	2700	4	7.5"
1.50	ITR12122111		130 (96)		3500		
1.81	ITR12122101		110 (81)				
2.65	ITR12122102		91 (67)				
4.09	ITR12122103		71 (52)				
0.57	ITR12122004	with BD112 PTO	161 (119)	24 (32)	2700	4	8.0"
1.50	ITR12122011		130 (96)		3500		
1.81	ITR12122001		110 (81)				
2.65	ITR12122002		91 (67)				
4.09	ITR12122003		71 (52)				
0.57	ITR12132004	with BD118 PTO	161 (119)	24 (32)	2700	4	8.0"
1.50	ITR12132011		130 (96)		3500		
1.81	ITR12132001		110 (81)				
2.65	ITR12132002		91 (67)				
4.09	ITR12132003		71 (52)				
0.57	ITR12231004	with BDS118 Remote PTO	161 (119)	24 (32)	2700	N/A	N/A
1.50	ITR12231011		130 (96)		3500		
1.81	ITR12231001		110 (81)				
2.65	ITR12231002		91 (67)				
4.09	ITR12231003		71 (52)				



WE PUT HORSEPOWER TO WORK

RM 70 SERIES

RM 70D FOR REVERSE DIRECTION AS ENGINE OUTPUT

Ratio (X:1)	Part Number	Configuration	Max. Input Torque Nm (lb-ft)	Max. Power Allowed Without H.E. kW (hp)	Maximum Input Shaft Speed	SAE Housing	Clutch Size
0.58	ITR13342015	Housing	290 (215)	48 (64)	2500	4	10.0"
1.00	ITR13342009		290 (215)		3200		
1.53	ITR13342008		250 (185)				
2.00	ITR13342010		210 (156)				
2.45	ITR13342014		190 (141)				
3.00	ITR13342011		170 (126)				
3.75	ITR13342012		155 (115)				
0.58	ITR13341015	Housing	290 (215)	48 (64)	2500	3	10.0"
1.00	ITR13341009		290 (215)		3200		
1.53	ITR13341008		250 (185)				
2.00	ITR13341010		210 (156)				
2.45	ITR13341014		190 (141)				
3.00	ITR13341011		170 (126)				
3.75	ITR13341012		155 (115)				
0.58	ITR13112015	with BD130 PTO	290 (215)	48 (64)	2500	4	10.0"
1.00	ITR13112009		290 (215)		3200		
1.53	ITR13112008		250 (185)				
2.00	ITR13112010		210 (156)				
2.45	ITR13112014		190 (141)				
3.00	ITR13112011		170 (126)				
3.75	ITR13112012		155 (115)				
0.58	ITR13111015	with BD130 PTO	290 (215)	48 (64)	2500	3	10.0"
1.00	ITR13111009		290 (215)		3200		
1.53	ITR13111008		250 (185)				
2.00	ITR13111010		210 (156)				
2.45	ITR13111014		190 (141)				
3.00	ITR13111011		170 (126)				
3.75	ITR13111012		155 (115)				
0.58	ITR13210015	with BDS130 Remote PTO	290 (215)	48 (64)	2500	N/A	N/A
1.00	ITR13210009		290 (215)		3200		
1.53	ITR13210008		250 (185)				
2.00	ITR13210010		210 (156)				
2.45	ITR13210014		190 (141)				
3.00	ITR13210011		170 (126)				
3.75	ITR13210012		155 (115)				

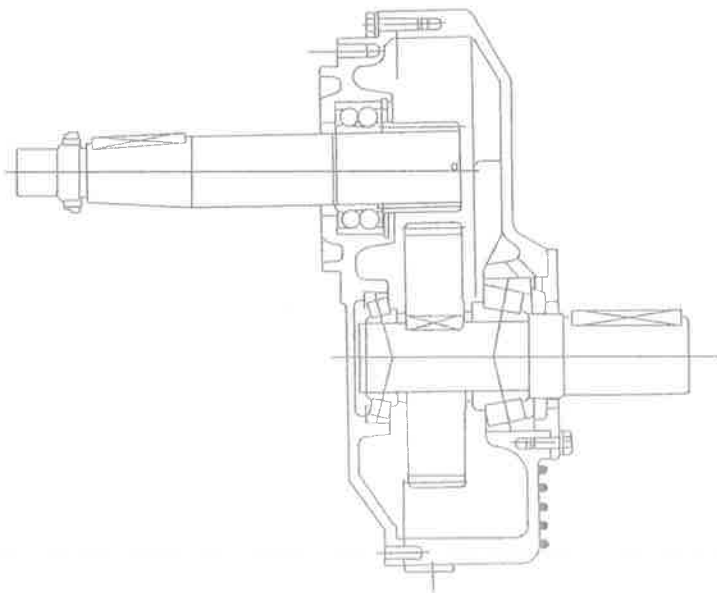
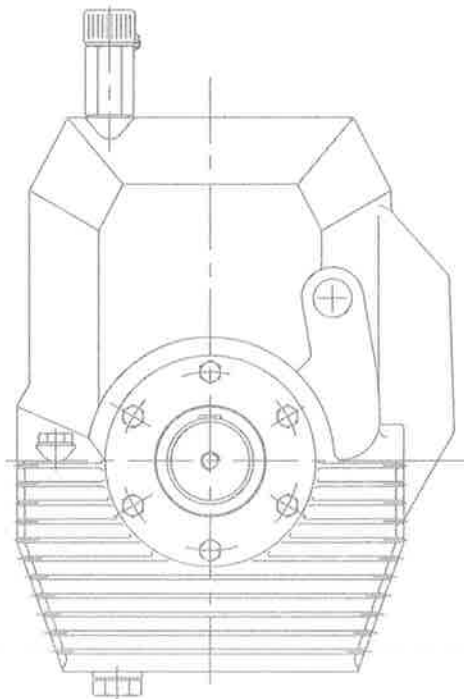

RM 70 SERIES

RM 70S FOR SAME DIRECTION AS ENGINE OUTPUT

Ratio (X:1)	Part Number	Configuration	Max. Input Torque Nm (lb-ft)	Max. Power Allowed Without H.E. kW (hp)	Maximum Input Shaft Speed	SAE Housing	Clutch Size
0.50	ITR13342004	Housing	280 (207)	38 (51)	2400	4	10.0"
0.63	ITR13342005		280 (207)		2600		
0.70	ITR13342006		260 (193)		2700		
1.32	ITR13342003		220 (163)		3200		
1.88	ITR13342001		200 (148)				
2.73	ITR13342002		160 (119)				
3.25	ITR13342016		120 (89)				
0.50	ITR13341004	Housing	280 (207)	38 (51)	2400	3	10.0"
0.63	ITR13341005		280 (207)		2600		
0.70	ITR13341006		260 (193)		2700		
1.32	ITR13341003		220 (163)		3200		
1.88	ITR13341001		200 (148)				
2.73	ITR13341002		160 (119)				
3.25	ITR13341016		120 (89)				
0.50	ITR13112004	with BD130 PTO	280 (207)	38 (51)	2400	4	10.0"
0.63	ITR13112005		280 (207)		2600		
0.70	ITR13112006		260 (193)		2700		
1.32	ITR13112003		220 (163)		3200		
1.88	ITR13112001		200 (148)				
2.73	ITR13112002		160 (119)				
3.25	ITR13112016		120 (89)				
0.50	ITR13111004	with BD130 PTO	280 (207)	38 (51)	2400	3	10.0"
0.63	ITR13111005		280 (207)		2600		
0.70	ITR13111006		260 (193)		2700		
1.32	ITR13111003		220 (163)		3200		
1.88	ITR13111001		200 (148)				
2.73	ITR13111002		160 (119)				
3.25	ITR13111016		120 (89)				
0.50	ITR13210004	with BDS130 Remote PTO	280 (207)	38 (51)	2400	N/A	N/A
0.63	ITR13210005		280 (207)		2600		
0.70	ITR13210006		260 (193)		2700		
1.32	ITR13210003		220 (163)		3200		
1.88	ITR13210001		200 (148)				
2.73	ITR13210002		160 (119)				
3.25	ITR13210016		120 (89)				



WE PUT HORSEPOWER TO WORK

RM 100 SERIES

RM 100D FOR REVERSE DIRECTION AS ENGINE OUTPUT

Ratio (X:1)	Part Number	Configuration	Max. Input Torque Nm (lb-ft)	Max. Power Allowed Without H.E. kW (hp)	Maximum Input Shaft Speed	SAE Housing	Clutch Size
0.60	ITR14342012	Housing	400 (296)	75 (100)	2400	4	10.0"
0.67	ITR14342013		400 (296)		2500		
1.00	ITR14342005		400 (296)		3000		
1.20	ITR14342009		380 (281)				
1.50	ITR14342010		350 (259)				
2.00	ITR14342006		320 (237)				
3.00	ITR14342007		260 (193)				
3.66	ITR14342019		230 (170)				
5.00	ITR14342008		230 (170)				
0.60	ITR14341012	Housing	400 (296)	75 (100)	2400	3	10.0"
0.67	ITR14341013		400 (296)		2500		
1.00	ITR14341005		400 (296)		3000		
1.20	ITR14341009		380 (281)				
1.50	ITR14341010		350 (259)				
2.00	ITR14341006		320 (237)				
3.00	ITR14341007		260 (193)				
3.66	ITR14341019		230 (170)				
5.00	ITR14341008		230 (170)				
0.60	ITR14351012	Housing	400 (296)	75 (100)	2400	3	11.5"
0.67	ITR14351013		400 (296)		2500		
1.00	ITR14351005		400 (296)		3000		
1.20	ITR14351009		380 (281)				
1.50	ITR14351010		350 (259)				
2.00	ITR14351006		320 (237)				
3.00	ITR14351007		260 (193)				
3.66	ITR14351019		230 (170)				
5.00	ITR14351008		230 (170)				
0.60	ITR14122012	with BD130 PTO	400 (296)	75 (100)	2400	4	10.0"
0.67	ITR14122013		400 (296)		2500		
1.00	ITR14122005		400 (296)		3000		
1.20	ITR14122009		380 (281)				
1.50	ITR14122010		350 (259)				
2.00	ITR14122006		320 (237)				
3.00	ITR14122007		260 (193)				
3.66	ITR14122019		230 (170)				
5.00	ITR14122008		230 (170)				
0.60	ITR14121012	with BD130 PTO	400 (296)	75 (100)	2400	3	10.0"
0.67	ITR14121013		400 (296)		2500		
1.00	ITR14121005		400 (296)		3000		
1.20	ITR14121009		380 (281)				
1.50	ITR14121010		350 (259)				
2.00	ITR14121006		320 (237)				
3.00	ITR14121007		260 (193)				
3.66	ITR14121019		230 (170)				
5.00	ITR14121008		230 (170)				
0.60	ITR14132012	with BDS145 PTO	400 (296)	75 (100)	2400	4	11.5"
0.67	ITR14132013		400 (296)		2500		
1.00	ITR14132005		400 (296)		3000		
1.20	ITR14132009		380 (281)				
1.50	ITR14132010		350 (259)				
2.00	ITR14132006		320 (237)				
3.00	ITR14132007		260 (193)				
3.66	ITR14132019		230 (170)				
5.00	ITR14132008		230 (170)				
0.60	ITR14131012	with BDS145 PTO	400 (296)	75 (100)	2400	3	11.5"
0.67	ITR14131013		400 (296)		2500		
1.00	ITR14131005		400 (296)		3000		
1.20	ITR14131009		380 (281)				
1.50	ITR14131010		350 (259)				
2.00	ITR14131006		320 (237)				
3.00	ITR14131007		260 (193)				
3.66	ITR14131019		230 (170)				
5.00	ITR14131008		230 (170)				
0.60	ITR14220012	with BDS130 Remote PTO	400 (296)	75 (100)	2400	N/A	N/A
0.67	ITR14220013		400 (296)		2500		
1.00	ITR14220005		400 (296)		3000		
1.20	ITR14220009		380 (281)				
1.50	ITR14220010		350 (259)				
2.00	ITR14220006		320 (237)				
3.00	ITR14220007		260 (193)				
3.66	ITR14220019		230 (170)				
5.00	ITR14220008		230 (170)				
0.60	ITR14230012	with BDS145 Remote PTO	400 (296)	75 (100)	2400	N/A	N/A
0.67	ITR14230013		400 (296)		2500		
1.00	ITR14230005		400 (296)		3000		
1.20	ITR14230009		380 (281)				
1.50	ITR14230010		350 (259)				
2.00	ITR14230006		320 (237)				
3.00	ITR14230007		260 (193)				
3.66	ITR14230019		230 (170)				
5.00	ITR14230008		230 (170)				

RM 100 SERIES

RM 100S FOR SAME DIRECTION AS ENGINE OUTPUT

Ratio (X:1)	Part Number	Configuration	Max. Input Torque Nm (lb-ft)	Max. Power Allowed Without H.E. kW (hp)	Maximum Input Shaft Speed	SAE Housing	Clutch Size
0.51	ITR14342004	Housing	400 (296)	60 (80)	2000	4	10.0"
0.81	ITR14342016		380 (281)		2700		
1.23	ITR14342017		380 (281)		3000		
1.50	ITR14342001		350 (259)				
1.86	ITR14342002		320 (237)				
2.80	ITR14342003		260 (193)				
4.21	ITR14342015		230 (170)				
0.51	ITR14341004	Housing	400 (296)	60 (80)	2000	3	10.0"
0.81	ITR14341016		380 (281)		2700		
1.23	ITR14341017		380 (281)		3000		
1.50	ITR14341001		350 (259)				
1.86	ITR14341002		320 (237)				
2.80	ITR14341003		260 (193)				
4.21	ITR14341015		230 (170)				
0.51	ITR14351004	Housing	400 (296)	60 (80)	2000	3	11.5"
0.81	ITR14351016		380 (281)		2700		
1.23	ITR14351017		380 (281)		3000		
1.50	ITR14351001		350 (259)				
1.86	ITR14351002		320 (237)				
2.80	ITR14351003		260 (193)				
4.21	ITR14351015		230 (170)				
0.51	ITR14122004	with BD130 PTO	400 (296)	60 (80)	2000	4	10.0"
0.81	ITR14122016		380 (281)		2700		
1.23	ITR14122017		380 (281)		3000		
1.50	ITR14122001		350 (259)				
1.86	ITR14122002		320 (237)				
2.80	ITR14122003		260 (193)				
4.21	ITR14122015		230 (170)				
0.51	ITR14121004	with BD130 PTO	400 (296)	60 (80)	2000	3	10.0"
0.81	ITR14121016		380 (281)		2700		
1.23	ITR14121017		380 (281)		3000		
1.50	ITR14121001		350 (259)				
1.86	ITR14121002		320 (237)				
2.80	ITR14121003		260 (193)				
4.21	ITR14121015		230 (170)				
0.51	ITR14132004	with BD145 PTO	400 (296)	60 (80)	2000	4	11.5"
0.81	ITR14132016		380 (281)		2700		
1.23	ITR14132017		380 (281)		3000		
1.50	ITR14132001		350 (259)				
1.86	ITR14132002		320 (237)				
2.80	ITR14132003		260 (193)				
4.21	ITR14132015		230 (170)				
0.51	ITR14131004	with BD145 PTO	400 (296)	60 (80)	2000	3	11.5"
0.81	ITR14131016		380 (281)		2700		
1.23	ITR14131017		380 (281)		3000		
1.50	ITR14131001		350 (259)				
1.86	ITR14131002		320 (237)				
2.80	ITR14131003		260 (193)				
4.21	ITR14131015		230 (170)				
0.51	ITR14220004	with BDS130 Remote PTO	400 (296)	60 (80)	2000	N/A	N/A
0.81	ITR14220016		380 (281)		2700		
1.23	ITR14220017		380 (281)		3000		
1.50	ITR14220001		350 (259)				
1.86	ITR14220002		320 (237)				
2.80	ITR14220003		260 (193)				
4.21	ITR14220015		230 (170)				
0.51	ITR14230004	with BDS145 Remote PTO	400 (296)	60 (80)	2000	N/A	N/A
0.81	ITR14230016		380 (281)		2700		
1.23	ITR14230017		380 (281)		3000		
1.50	ITR14230001		350 (259)				
1.86	ITR14230002		320 (237)				
2.80	ITR14230003		260 (193)				
4.21	ITR14230015		230 (170)				



RM 120 SERIES

RM 120D FOR REVERSE DIRECTION AS ENGINE OUTPUT

Ratio (X:1)	Part Number	Configuration	Max. Input Torque Nm (lb-ft)	Max. Power Allowed Without H.E. kW (hp)	Maximum Input Shaft Speed	SAE Housing	Clutch Size
0.50	ITR15353010	Housing	1000 (741)	85 (113)	2000	3	11.5"
1.02	ITR15353002		880 (652)		2500		
1.70	ITR15353009		740 (548)				
2.00	ITR15353003		700 (519)				
3.00	ITR15353004		510 (378)				
3.55	ITR15353014		450 (333)				
0.50	ITR15352010	Housing	1000 (741)	85 (113)	2000	2	11.5"
1.02	ITR15352002		880 (652)		2500		
1.70	ITR15352009		740 (548)				
2.00	ITR15352003		700 (519)				
3.00	ITR15352004		510 (378)				
3.55	ITR15352014		450 (333)				
0.50	ITR15351010	Housing	1000 (741)	85 (113)	2000	1	11.5"
1.02	ITR15351002		880 (652)		2500		
1.70	ITR15351009		740 (548)				
2.00	ITR15351003		700 (519)				
3.00	ITR15351004		510 (378)				
3.55	ITR15351014		450 (333)				
0.50	ITR15124010	with BD145 PTO	1000 (741)	85 (113)	2000	4	11.5"
1.02	ITR15124002		880 (652)		2500		
1.70	ITR15124009		740 (548)				
2.00	ITR15124003		700 (519)				
3.00	ITR15124004		510 (378)				
3.55	ITR15124014		450 (333)				
0.50	ITR15123010	with BD145 PTO	1000 (741)	85 (113)	2000	3	11.5"
1.02	ITR15123002		880 (652)		2500		
1.70	ITR15123009		740 (548)				
2.00	ITR15123003		700 (519)				
3.00	ITR15123004		510 (378)				
3.55	ITR15123014		450 (333)				
0.50	ITR15133010	with BD290 PTO	1000 (741)	85 (113)	2000	3	11.5"
1.02	ITR15133002		880 (652)		2500		
1.70	ITR15133009		740 (548)				
2.00	ITR15133003		700 (519)				
3.00	ITR15133004		510 (378)				
3.55	ITR15133014		450 (333)				
0.50	ITR15132010	with BD290 PTO	1000 (741)	85 (113)	2000	2	11.5"
1.02	ITR15132002		880 (652)		2500		
1.70	ITR15132009		740 (548)				
2.00	ITR15132003		700 (519)				
3.00	ITR15132004		510 (378)				
3.55	ITR15132014		450 (333)				
0.50	ITR15131010	with BD290 PTO	1000 (741)	85 (113)	2000	1	11.5"
1.02	ITR15131002		880 (652)		2500		
1.70	ITR15131009		740 (548)				
2.00	ITR15131003		700 (519)				
3.00	ITR15131004		510 (378)				
3.55	ITR15131014		450 (333)				
0.50	ITR15220010	with BDS145 Remote PTO	1000 (741)	85 (113)	2000	N/A	N/A
1.02	ITR15220002		880 (652)		2500		
1.70	ITR15220009		740 (548)				
2.00	ITR15220003		700 (519)				
3.00	ITR15220004		510 (378)				
3.55	ITR15220014		450 (333)				
0.50	ITR15230010	with BDS290 Remote PTO	1000 (741)	85 (113)	2000	N/A	N/A
1.02	ITR15230002		880 (652)		2500		
1.70	ITR15230009		740 (548)				
2.00	ITR15230003		700 (519)				
3.00	ITR15230004		510 (378)				
3.55	ITR15230014		450 (333)				

RM 120 SERIES

RM 120S FOR SAME DIRECTION AS ENGINE OUTPUT

Ratio (x:1)	Part Number	Configuration	Max. Input Torque Nm (lb-ft)	Max. Power Allowed Without H.E. kW (hp)	Maximum Input Shaft Speed	SAE Housing	Clutch Size
0.67	ITR15353001	Housing	830 (615)	68 (91)	2000	3	11.5"
1.50	ITR15353006		500 (370)				
2.00	ITR15353007		480 (356)				
2.60	ITR15353011		480 (356)				
2.80	ITR15353005		480 (356)				
3.00	ITR15353008		480 (356)				
0.67	ITR15352001	Housing	830 (615)	68 (91)	2000	2	11.5"
1.50	ITR15352006		500 (370)				
2.00	ITR15352007		480 (356)				
2.60	ITR15352011		480 (356)				
2.80	ITR15352005		480 (356)				
3.00	ITR15352008		480 (356)				
0.67	ITR15351001	Housing	830 (615)	68 (91)	2000	1	11.5"
1.50	ITR15351006		500 (370)				
2.00	ITR15351007		480 (356)				
2.60	ITR15351011		480 (356)				
2.80	ITR15351005		480 (356)				
3.00	ITR15351008		480 (356)				
0.67	ITR15124001	with BD145 PTO	830 (615)	68 (91)	2000	4	11.5"
1.50	ITR15124006		500 (370)				
2.00	ITR15124007		480 (356)				
2.60	ITR15124011		480 (356)				
2.80	ITR15124005		480 (356)				
3.00	ITR15124008		480 (356)				
0.67	ITR15123001	with BD145 PTO	830 (615)	68 (91)	2000	3	11.5"
1.50	ITR15123006		500 (370)				
2.00	ITR15123007		480 (356)				
2.60	ITR15123011		480 (356)				
2.80	ITR15123005		480 (356)				
3.00	ITR15123008		480 (356)				
0.67	ITR15133001	with BD290 PTO	830 (615)	68 (91)	2000	3	11.5"
1.50	ITR15133006		500 (370)				
2.00	ITR15133007		480 (356)				
2.60	ITR15133011		480 (356)				
2.80	ITR15133005		480 (356)				
3.00	ITR15133008		480 (356)				
0.67	ITR15132001	with BD290 PTO	830 (615)	68 (91)	2000	2	11.5"
1.50	ITR15132006		500 (370)				
2.00	ITR15132007		480 (356)				
2.60	ITR15132011		480 (356)				
2.80	ITR15132005		480 (356)				
3.00	ITR15132008		480 (356)				
0.67	ITR15131001	with BD290 PTO	830 (615)	68 (91)	2000	1	11.5"
1.50	ITR15131006		500 (370)				
2.00	ITR15131007		480 (356)				
2.60	ITR15131011		480 (356)				
2.80	ITR15131005		480 (356)				
3.00	ITR15131008		480 (356)				
0.67	ITR15220001	with BDS145 Remote PTO	830 (615)	68 (91)	2000	N/A	N/A
1.50	ITR15220006		500 (370)				
2.00	ITR15220007		480 (356)				
2.60	ITR15220011		480 (356)				
2.80	ITR15220005		480 (356)				
3.00	ITR15220008		480 (356)				
0.67	ITR15230001	with BDS290 Remote PTO	830 (615)	68 (91)	2000	N/A	N/A
1.50	ITR15230006		500 (370)				
2.00	ITR15230007		480 (356)				
2.60	ITR15230011		480 (356)				
2.80	ITR15230005		480 (356)				
3.00	ITR15230008		480 (356)				



RM 150 SERIES

RM 150D FOR REVERSE DIRECTION AS ENGINE OUTPUT
RM 150S FOR SAME DIRECTION AS ENGINE OUTPUT

RM 150D – series (Reversing Gearboxes)

Ratio (X:1)	Part Number	Configuration	Max. Input Torque Nm (lb-ft)	Max. Power Allowed Without H.E. kW (hp)	Maximum Input Shaft Speed	SAE Housing	Clutch Size
0.66	ITR16352009	Housing	1500 (1111)	100 (133)	2000	2	11.5"
1.02	ITR16352005		1450 (1074)		2500		
1.47	ITR16352012		1250 (926)				
2.00	ITR16352006		1090 (807)				
3.04	ITR16352007		850 (630)				
0.66	ITR16133009	with BD290 PTO	1500 (1111)	100 (133)	2000	3	11.5"
1.02	ITR16133005		1450 (1074)		2500		
1.47	ITR16133012		1250 (926)				
2.00	ITR16133006		1090 (807)				
3.04	ITR16133007		850 (630)				
0.66	ITR16132009	with BD290 PTO	1500 (1111)	100 (133)	2000	2	11.5"
1.02	ITR16132005		1450 (1074)		2500		
1.47	ITR16132012		1250 (926)				
2.00	ITR16132006		1090 (807)				
3.04	ITR16132007		850 (630)				
0.66	ITR16131009	with BD290 PTO	1500 (1111)	100 (133)	2000	1	11.5"
1.02	ITR16131005		1450 (1074)		2500		
1.47	ITR16131012		1250 (926)				
2.00	ITR16131006		1090 (807)				
3.04	ITR16131007		850 (630)				
0.66	ITR16151009	with BD2200 PTO	1500 (1111)	100 (133)	2000	1	14.0"
1.02	ITR16151005		1450 (1074)		2500		
1.47	ITR16151012		1250 (926)				
2.00	ITR16151006		1090 (807)				
3.04	ITR16151007		850 (630)				
0.66	ITR16230009	with BDS290 Remote PTO	1500 (1111)	100 (133)	2000	N/A	N/A
1.02	ITR16230005		1450 (1074)		2500		
1.47	ITR16230012		1250 (926)				
2.00	ITR16230006		1090 (807)				
3.04	ITR16230007		850 (630)				
0.66	ITR16250009	with BDS2200 Remote PTO	1500 (1111)	100 (133)	2000	N/A	N/A
1.02	ITR16250005		1450 (1074)		2500		
1.47	ITR16250012		1250 (926)				
2.00	ITR16250006		1090 (807)				
3.04	ITR16250007		850 (630)				

RM 150S – series (Same Direction Gearboxes)

Ratio (X:1)	Part Number	Configuration	Max. Input Torque Nm (lb-ft)	Max. Power Allowed Without H.E. kW (hp)	Maximum Input Shaft Speed	SAE Housing	Clutch Size
1.51	ITR16352003	Housing	950 (704)	80 (107)	2500	2	11.5"
1.96	ITR16352001		950 (704)				
2.70	ITR16352002		640 (474)				
1.51	ITR16361003	Housing	950 (704)	80 (107)	2500	1	14.0"
1.96	ITR16361001		950 (704)				
2.70	ITR16361002		640 (474)				
1.51	ITR16133003	with BD290 PTO	950 (704)	80 (107)	2500	3	11.5"
1.96	ITR16133001		950 (704)				
2.70	ITR16133002		640 (474)				
1.51	ITR16132003	with BD290 PTO	950 (704)	80 (107)	2500	2	11.5"
1.96	ITR16132001		950 (704)				
2.70	ITR16132002		640 (474)				
1.51	ITR16131003	with BD290 PTO	950 (704)	80 (107)	2500	1	11.5"
1.96	ITR16131001		950 (704)				
2.70	ITR16131002		640 (474)				
1.51	ITR16151003	with BD2200 PTO	950 (704)	80 (107)	2500	1	14.0"
1.96	ITR16151001		950 (704)				
2.70	ITR16151002		640 (474)				
1.51	ITR16230003	with BDS290 Remote PTO	950 (704)	80 (107)	2500	N/A	N/A
1.96	ITR16230001		950 (704)				
2.70	ITR16230002		640 (474)				
1.51	ITR16250003	with BDS2200 Remote PTO	950 (704)	80 (107)	2500	N/A	N/A
1.96	ITR16250001		950 (704)				
2.70	ITR16250002		640 (474)				



REDUCTION GEARS & SPEED INCREASERS SPECIFICATIONS

Model	Direction	Ratio (X:1)	Max. Input Torque Nm (lb-ft)	Max. Power Allowed Without H.E. kW (hp)	Maximum Input Shaft Speed	SAE Housings Available	Clutch Sizes Available
RM20D	Reverse	0.57	75 (56)	15 (20)	2700	5, 4	6.5", 7.5"
		1.00	75 (56)		3500		
		2.00	55 (41)				
		2.71	50 (37)				
RM20S	Same	0.64	75 (56)	12 (16)	2800	5, 4	6.5", 7.5"
		1.89	55 (41)		3500		
		2.47	50 (37)				
RM45D	Reverse	0.67	165 (122)	30 (40)	2800	5, 4	6.5", 7.5", 8.0"
		1.00	160 (119)		3500		
		2.00	120 (89)				
		2.88	100 (74)				
		3.40	80 (59)				
		4.00	80 (59)				
		5.00	70 (52)				
RM45S	Same	0.57	160 (119)	24 (32)	2700	5, 4	6.5", 7.5", 8.0"
		1.50	130 (96)		3500		
		1.81	110 (81)				
		2.65	90 (67)				
		4.09	70 (52)				
RM70D	Reverse	0.58	290 (215)	48 (64)	2500	4, 3	10.0"
		1.00	290 (215)		3200		
		1.53	250 (185)				
		2.00	210 (156)				
		2.45	190 (141)				
		3.00	170 (126)				
		3.75	155 (115)				
RM70S	Same	0.50	280 (207)	38 (51)	2400	4, 3	10.0"
		0.63	280 (207)		2600		
		0.70	260 (193)				
		1.32	220 (163)		3200		
		1.88	200 (148)				
		2.73	160 (119)				
		3.25	120 (89)				
		0.60	400 (296)				
0.67	400 (296)	2500					
1.00	400 (296)						
1.20	380 (281)						
1.50	350 (259)						
2.00	320 (237)						
3.00	260 (193)						
3.66	230 (170)						
5.00	230 (170)						
RM100S	Same	0.51	400 (296)	60 (80)	2000	4, 3	10.0", 11.5"
		0.81	380 (281)		2700		
		1.23	380 (281)				
		1.50	350 (259)		3000		
		1.86	320 (237)				
		2.80	260 (193)				
		4.21	230 (170)				
RM120D	Reverse	0.50	1000 (741)	85 (114)	2000	4, 3, 2, 1	11.5"
		1.02	880 (652)		2500		
		1.70	740 (548)				
		2.00	700 (519)				
		3.00	510 (378)				
		3.55	450 (333)				
RM120S	Same	0.67	830 (615)	68 (91)	2000	4, 3, 2, 1	11.5"
		1.50	500 (370)		2500		
		2.00	480 (356)				
		2.60	480 (356)				
		2.80	480 (356)				
		3.00	480 (356)				
RM150D	Reverse	0.66	1500 (1111)	100 (134)	2000	3, 2, 1	11.5", 14.0"
		1.02	1450 (1074)		2500		
		1.47	1250 (926)				
		2.00	1090 (807)				
		3.04	850 (630)				
RM150S	Same	1.51	950 (704)	80 (107)	2500	3, 2, 1	11.5", 14.0"
		1.96	950 (704)				
		2.70	640 (474)				