

High performance directional valve, ISO size 3
Solenoid controlled, 2-stage
Series WEVDK ...



- 350 bar, 100 l/min
- High switching reliability thanks to spool operation
- Unaffected by:
 - asymmetric flow paths
 - long periods under high pressure w
 - large pressure drops across the spool lands
 - low supply voltage
- High flow rates
- Good Δp -Q characteristics
- Pressure in P, A and B to 350 bar
- Wet armature design, change coils without opening hydraulic envelope
- With manual override
- Mounting interface to ISO 4401 / CETOP R35H size 3, NFPA D03, DIN 24 340 A6

1. Description

Series WEVDK ...-6 high performance spool valves are internally piloted and use the follower spool principle. The main valve components are a cast body, a spring-centered follower spool assembly and wet armature solenoids with pressure-tight core tube and slip-on coil. These valves provide reliable service even under the severest operating conditions such as very high flow rates, high operating pressures, supply voltage drops, long periods without switching, large and sudden changes in fluid temperature etc. The highly effective spool actuation method

combines the advantages of direct acting and two-stage solenoid valves, without incurring the well known disadvantages of either type. The main spool is offset by both the solenoid force and the $P \Rightarrow T$ *) pressure difference inside the valve. The greater the $P \Rightarrow T$ pressure difference, the greater the offsetting force. The spool is returned to the mid-position in the same way, using the $P \Rightarrow T$ pressure difference and without the need for the usual heavy centering springs. If very low flow rates, or an open circuit condition, result in there being no $P \Rightarrow T$ pressure difference,

then the spool actuation reverts to the normal solenoid / centering spring arrangement. The manual over-ride, which is fitted as standard equipment to all valves, can be operated even when high tank line back-pressures exist in the core tube.

*) The pressure in P must always be equal to, or greater than, that in T and the valve must be connected in the conventional manner i.e. pressure to P, T to tank.

2. Symbols

4/2 FUNCTIONS	4/2 FUNCTIONS WITH 4/3 SPOOLS	4/2 FUNCTIONS WITH 4/3 SPOOLS	4/3 FUNCTIONS
WEVDK-42-A-6 ... 1 	WEVDK-42-AD-6 5 	WEVDK-42-BD-6 9 	WEVDK-43-D-6 13
WEVDK-42-B-6 ... 2 	WEVDK-42-AG-6 6 	WEVDK-42-BG-6 10 	WEVDK-43-G-6 14
Crossover transients 3 	WEVDK-42-AH-6 7 	WEVDK-42-BH-6 11 	WEVDK-43-H-6 15
WEVDK-42-C-6 ... 4 	WEVDK-42-AJ-6 8 	WEVDK-42-BJ-6 12 	WEVDK-43-J-6 16

3. Characteristics

Type		high performance 4/2 and 4/3 directional valve
Design		combined direct acting and 2-stage
Mounting method		manifold mounting
Size		nominal size 6 mm, ISO 4401 size 3 interface
Mass	kg	1,6 (1 solenoid), 2,1 (2 solenoids)
Mounting attitude		unrestricted (Vertical mounting makes air bleeding difficult)
Flow direction		see symbols
Operating pressure in P, A und B	bar	max. 350
Operating pressure in T (static)	bar	max. 80
Flow rate Qmax	l/min	0 ... 100 l/min (see Δp -Q characteristics)
Pilot oil consumption P -> T	cm ³ /min	at 50 bar = 40; at 200 bar = 100
Fluids		Hydraulic oils HL and HLP to DIN 51 524 - for other fluids consult BUCHER
Fluid temperature range	°C	-25 ... + 80
Ambient temperature	°C	-25 ... + 50
Viscosity range	cSt	10 ... 500, recommended 15 ... 250
Minimum fluid cleanliness		18/14 to ISO 4406 /CETOP RP70H 8 ... 9 to NAS 1638
Standard voltages	VAC VDC	115, 230 40...60 Hz 12, 24
Nom. voltage tolerance	%	+ 5 / - 10
Nom. power consumption	VDC	12: 38 W; 24: 32 W
Duty cycle	% ED	100
Enclosure protection		IP 65 to DIN 40 050
Electrical connection		3-pin square plug to DIN43 650 / ISO 4400

4. Performance graphs

Oil viscosity 36 cSt

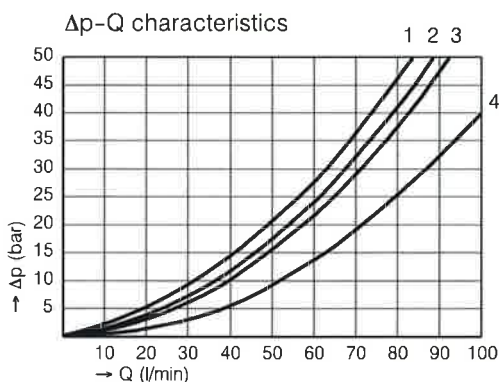

	P ⇒ A	B ⇒ T		P ⇒ B	A ⇒ T		P ⇒ T
		Sol. OFF	Sol. ON		Sol. OFF	Sol. ON	
A spool	4	2	--	4	--	2	--
D spool	4	--	2	4	--	2	--
G spool	4	2	2	4	2	2	--
H spool	4	2	4	4	2	4	-
J spool	1	--	1	1	--	1	3

Switching times
measured with:
24 VDC solenoid
5% under-voltage,
coil at steady-state
temperature.

Solenoid ON	100 ... 350 ms
Solenoid OFF	180 ... 550 ms

These are guideline values only, and can be significantly affected by flow rate and pressure. To achieve switching times which are largely unaffected by variations in supply voltage and coil temperature, we recommend our type LRS Power Reducing connector plug.
Contact BUCHER for application assistance.

5. Dimensions

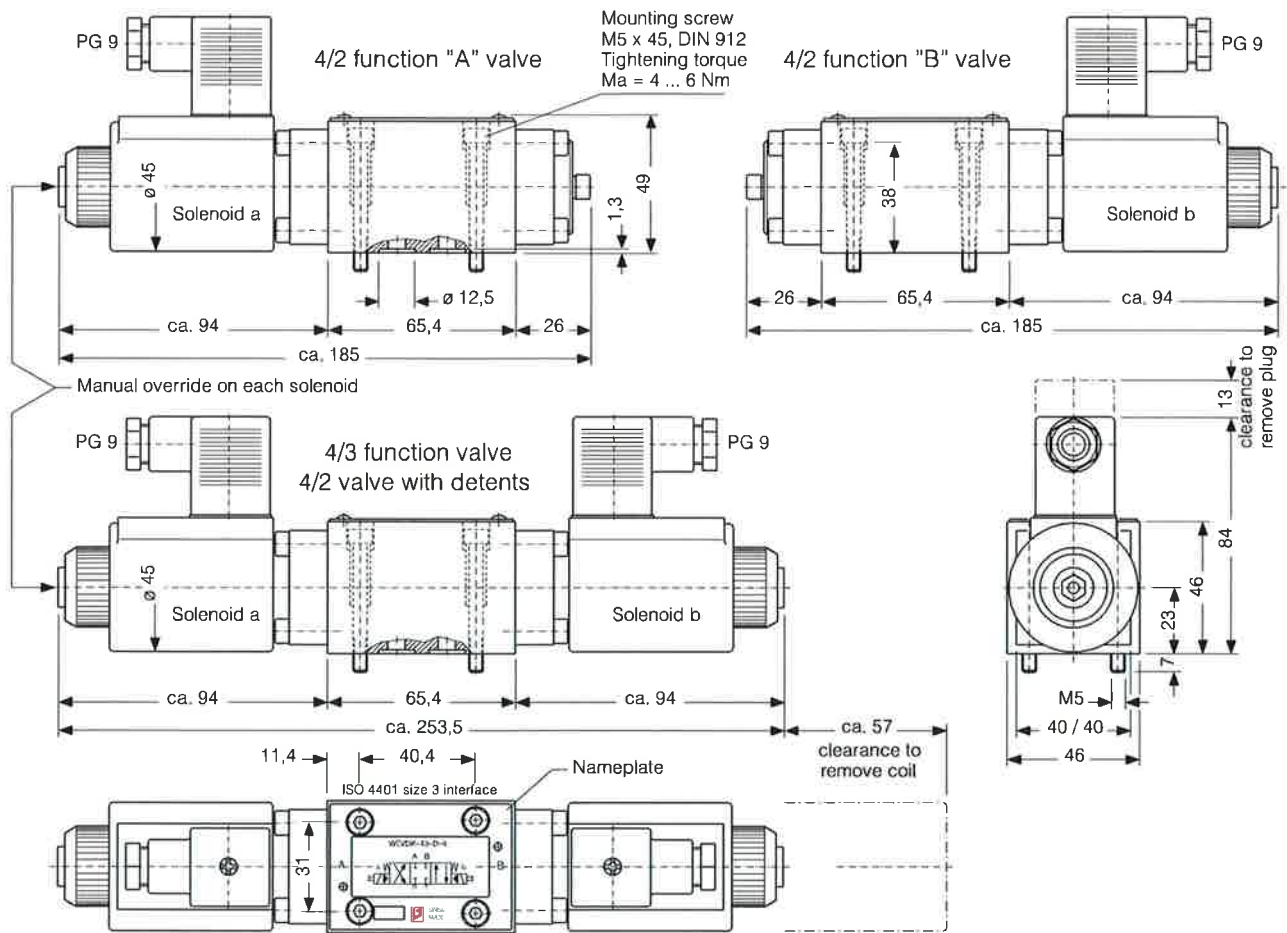

6. Schematic section

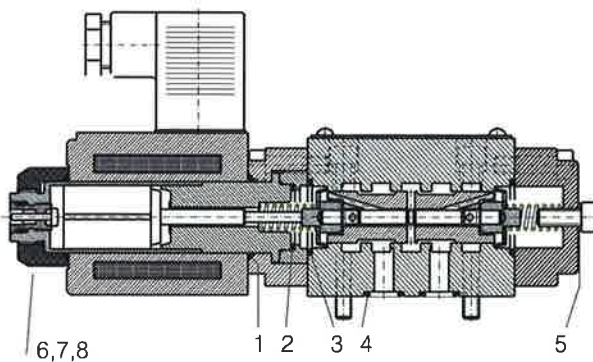

Seal kit no. DS-067, comprising:

ltn.	Qty.	Qty.	Description	Size
1	4	2	O-ring no. 019	Ø 20,35 x 1,78 N70
2	2	1	O-ring no. 016	Ø 15,60 x 1,78 N90
3	2	2	O-ring no. 018	Ø 18,77 x 1,78 N70
4	4	4	O-ring no. 012	Ø 9,25 x 1,78 N90
5	-	1	Copper ring	Ø 8,00/5,50x1,00 DIN7603A
6	2	2	O-ring	Ø 2,0 x 1,5V
7	2	2	O-ring	Ø 6,0 x 1,5V
8	2	2	Backup ring	Ø 5,3x1,2x0,8 FI0751

4/2 valves (1 solenoid)
4/2 valves with detents (2 solenoids)
4/3 valves (2 solenoids)

7. Model code key

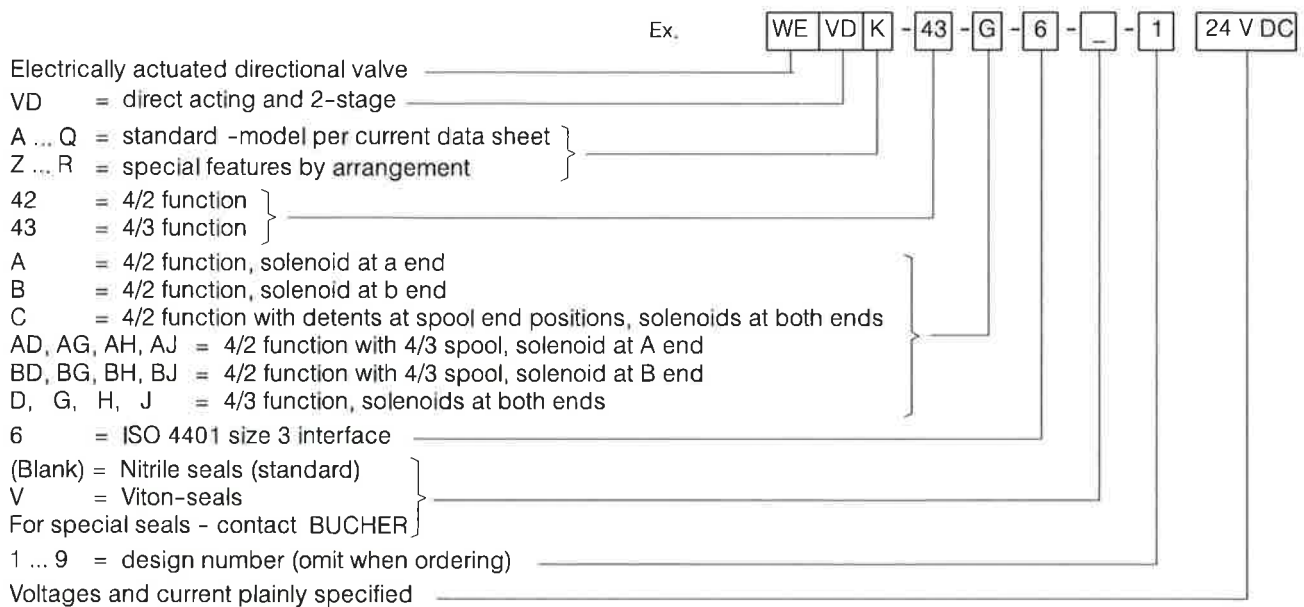

8. Related data sheets

Old no.	New no.	
i-00	400-P-010101-E	Table of interface equivalents
i-31	400-P-030501-E	DIN 24 340 size A6 interface
P-20	400-P-515101-E	LRS Power Reducing DIN plug
W-01	400-P-102100-E	High Performance Spool Valves /Principles/Overview

info.ch@bucherhydraulics.com

www.bucherhydraulics.com

© 2015 by Bucher Hydraulics AG Frutigen, CH-3714 Frutigen

All rights reserved.

Data is provided for the purpose of product description only, and must not be construed as warranted characteristics in the legal sense. The information does not relieve users from the duty of conducting their own evaluations and tests. Because the products are subject to continual improvement, we reserve the right to amend the product specifications contained in this catalogue.