

## Check Valve, ISO Size 07

$Q_{max} = 300 \text{ l/min}$ ,  $p_{max} = 350 \text{ bar}$

Sandwich design, pilot operated, seated pilot stage

Series SREA...

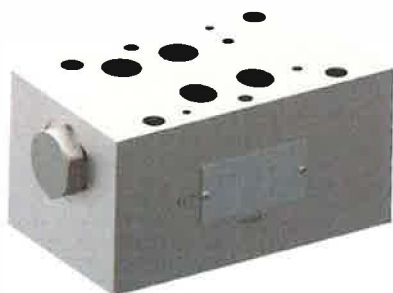

- Leak-free shut-off of actuator ports; optionally just one, or both
- Interface to ISO 4401-07-07
- Option of 2 different opening pressures
- Sandwich body is zinc-phosphated
- For use in stack-valve assemblies

### 1 Description

These pilot-operated check valves are high performance sandwich valves with a size 07 interface to ISO 4401-07-07. Thanks to the conical-seat design, the valves provide leak-free shut-off of the actuator ports (optionally in the A, B, or A and B lines). Two different models are available, with opening pressures of 2 bar and 5 bar respectively. These sandwich check valves are predominantly used in stack-valve assemblies in industrial applications to maintain the position

of loaded actuators (e.g. cylinders or motors) after the pump pressure has been disconnected. The sandwich body is zinc-phosphated. Alle übrigen Aussenteile sind verzinkt, chromitiert (Chrom VI-frei), wodurch sie sich auch bei extremen äusseren Bedingungen einsetzen lassen. The sandwich body is sealed at its manifold side (the connections side) by means of O-rings fitted in counterbores.

### 2 Symbol

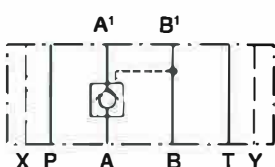

SREA-A-16...

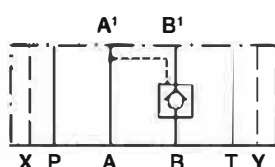

SREA-B-16...

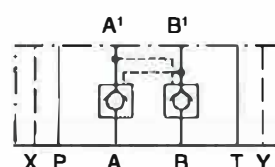

SREA-AB-16...

### 3 Technical data

General characteristics	Description, value, unit
Designation	check valve
Design	sandwich design, pilot operated, seated pilot stage
Mounting method	4 x $\varnothing 10.5$ holes for M10 cap screws 2 x $\varnothing 7$ holes for M6 cap screws
Size	size 07 interface to ISO 4401-07-07 / DIN 24 340 A16
Weight	7.65 kg
Mounting attitude	unrestricted
Ambient temperature range	-25 °C ... +80 °C

Hydraulic characteristics	Description, value, unit
Maximum operating pressure	350 bar
Maximum flow rate	300 l/min
Flow direction	shut-off direction A → A <sup>1</sup> or B → B <sup>1</sup> leak-free, check-valve function A <sup>1</sup> → A or B <sup>1</sup> → B
Opening pressure in free-flow direction	2 or 5 bar (A <sup>1</sup> → A)
Geometric opening ratio	1 : 13
Hydraulic fluid	HL and HLP mineral oil to DIN 51 524; for other fluids, please contact BUCHER
Hydraulic fluid temperature range	-25 °C ... +80 °C
Viscosity range	10...650 mm <sup>2</sup> /s (cSt), recommended 15...250 mm <sup>2</sup> /s (cSt)
Minimum fluid cleanliness Cleanliness class to ISO 4406 : 1999	class 20/18/15

### 4 Dimensions & sectional view

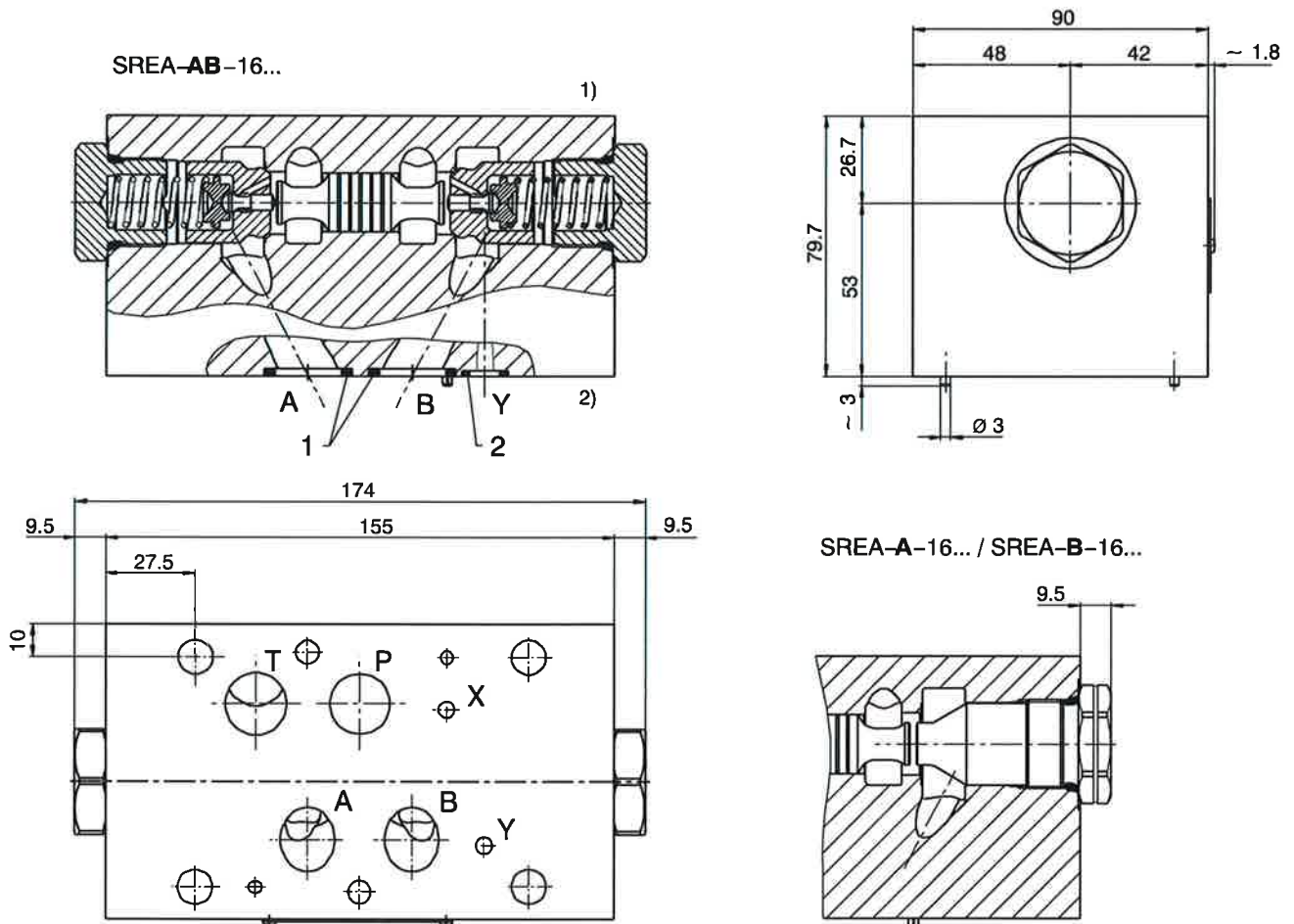

- 1) Valve side
- 2) Connections side (manifold side)



#### IMPORTANT!

In models in which only one actuator line (A or B) is provided with a check function, the other line is equipped with a blanking plug.

## 5 Performance graphs

measured with oil viscosity 33 mm<sup>2</sup>/s (cSt)

$\Delta p = f(Q)$  Pressure drop - Flow rate characteristic

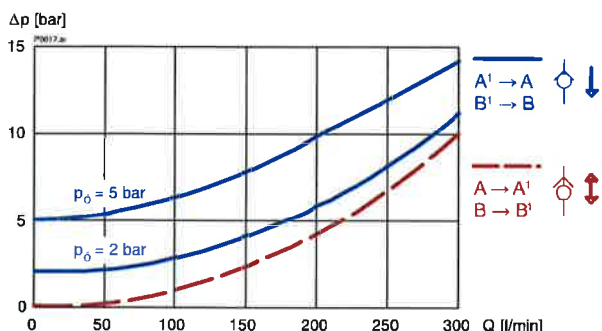

## 6 Installation information



### IMPORTANT!

When installing the valve, make sure that the mating face (the manifold interface) aligns with the valve interface. Do not confuse the sandwich valve's manifold side and directional-valve side. No adjustments are necessary, since the cartridges are set in the factory.



### ATTENTION!

Only qualified personnel with mechanical skills may carry out any maintenance work. Generally, the only work that should ever be undertaken is to check, and possibly replace, the seals. When changing seals, oil or grease the new seals thoroughly before fitting them.

Seal kit no. DS-356-N

Item	Qty.	Description
1	4	O-ring no. 118 $\varnothing$ 21.89 x 2.62 N90
2	2	O-ring $\varnothing$ 10.00 x 2.00 N90
2	2	O-ring no. 110 $\varnothing$ 9.19 x 2.62 N90

## 7 Ordering code

- S = sandwich design
- R = check valve
- E = piloted operated to open
- A ... Q = standard model - see relevant data sheets
- Z ... R = special features - please consult BUCHER
- A = function in A
- B = function in B
- AB = function in A and B
- 16 = ISO size 07 interface
- 02 = opening pressure 2,0 bar (standard)
- 05 = opening pressure 5,0 bar
- (blank) = NBR (Nitrile) seals (standard)
- V = FKM (Viton) seals (special seals - please contact BUCHER)
- 1 ... 9 = design stage (omit when ordering new units)

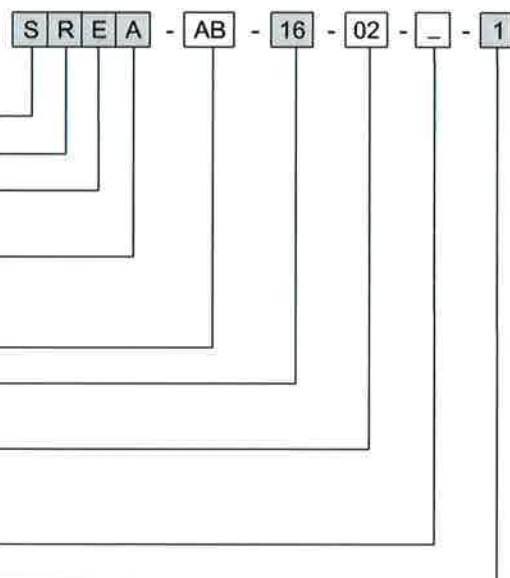

## 8 Related data sheets

Reference	(Old no.)	Description
400-P-070101	(i-51)	Size 07 interface to ISO 4401-07-07

info.ch@bucherhydraulics.com

www.bucherhydraulics.com

© 2015 by Bucher Hydraulics AG Frutigen, CH-3714 Frutigen

All rights reserved.

Data is provided for the purpose of product description only, and must not be construed as warranted characteristics in the legal sense. The information does not relieve users from the duty of conducting their own evaluations and tests. Because the products are subject to continual improvement, we reserve the right to amend the product specifications contained in this catalogue.

Classification: 430.315.345.330.305.335